

# iSpring RCS5T Reverse Osmosis Water Filtration System

## INSTALLATION INSTRUCTIONS & OPERATING MANUAL Ver. 05/2021



**1|2|3** **Filter.com**  
iSpring Water Systems, LLC (since 2005)

Copyright ©2005-2021 ISPRING WATER SYSTEMS, LLC. All rights reserved.





*We stand behind our products*

Since 2005, iSpring has been dedicated to providing high-quality drinking water to families across the United States. We provide various residential faucets and water filtration systems that purify your water in everyday life and deliver pure, healthy, and tasty water to you and your family.

At iSpring, we strive to develop products to the highest of standards and aim to make excellent drinking water accessible for all households. With affordable pricing, reliable quality, prompt delivery, and top-notch customer service, we hope to assist in bringing you great water for years to come.

## Prior to Installation

Read this instruction manual carefully prior to installation.

Keep this manual readily available for future reference.

# Table of Contents

<b>Before Installation</b> .....	3
Inspect the Package.....	3
Recommended Tools List.....	3
Operating Conditions.....	3
<b>Components Identification</b> .....	4
<b>Installation Tips</b> .....	5
How to Use Quick-connect Fitting .....	5
To Connect:.....	6
To Disconnect: .....	6
How to Use Compression Fitting with Brass Nut, Collar, and Tube Insert.....	6
How to Drill a Hole in Sink or Counter-top .....	7
Ice Maker Kit.....	7
<b>Installation Steps</b> .....	8
Step 1: Install Feed Water Adapter (AFW) .....	8
Step 2: Install Drinking Water Faucet .....	9
Step 3: Install Drain Saddle .....	9
Step 4: Install the Vertical Filters: Stages 1, 2, and 3 .....	10
Step 5: Install Tank Shut-off Valve (Optional).....	10
Step 6: Install Reverse Osmosis Membrane .....	10
Step 7: Tubing Hook Up (model specific sub-steps are marked with * ) .....	11
Step 8: System Start Up (model specific sub-steps are marked with * ) .....	12
<b>System Maintenance</b> .....	13
Stages 1 – 3 Pre-filters: Replace every 6 – 12 months, depending on source water quality and clean water usage. ....	13
How to Change In-housing Cartridges in 1 <sup>st</sup> – 3 <sup>rd</sup> Pre-filter Stages .....	13
Stage 4 RO Membrane: Replace Every 2 – 3 Years or Sooner if TDS Level Starts Increasing. ....	14
How to Change Reverse Osmosis Membrane.....	14
Stage 5 T33 Fine Carbon: Replace Every 12 Months.....	14
How to Change Inline Cartridges in 5 <sup>th</sup> – 7 <sup>th</sup> Stages .....	14
O-rings: Replace Every 3 Years or Sooner if Leak Happens at O-ring.....	15
<b>Extra Installation</b> .....	15
UV Lamp (part# iSpring UVB11) and Ice Maker Kit (part# iSpring ICEK) .....	15
<b>Warranty Registration</b> .....	16

## **Before Installation**

### ***Inspect the Package***

Please open the box and take all the components and tool kit out. Inspect them to ensure that nothing is damaged during shipping. If any part is cracked or broken, please immediately contact iSpring Customer Support for replacement. Identify and get familiar with the components.

### ***Recommended Tools List***

- Variable speed drill with two bits: 1/4" (for drilling a hole on PVC drain pipe), 1/2" hollow diamond (for drilling a hole on countertop for drinking faucet)
- 5/8", 9/16" open-end wrench, or adjustable wrench, pliers
- Phillips screwdriver
- Scissors or utility knife

### ***Operating Conditions***

- Maximum water pressure: 80 psi, or pressure regulator (part# APR70) is required if there is high water pressure or water hammer.
- Minimum water pressure: 40 psi, or booster pump is needed to improve RO efficiency
- Water temperature: 40 – 100 °F (4 - 37 °C) (This RO system is NOT designed for HOT water.)
- Maximum TDS: 750 ppm
- Install this RO system at a location where it is safe from hot/cold weather and direct sunlight. Avoid hitting, dropping, or dragging as they may cause cracks and leaks.

# Components Identification



Pre-assembled RO System (membrane not yet installed, filter cartridges are still wrapped)



Sediment Filter x 1  
Granular Activated Carbon Filter x 1  
Carbon Block Filter x 1



500 GPD Side-flow RO Membrane



FT15 5th Stage Inline Post Carbon Filter



Drinking Faucet



Drain Saddle



Feed Water Adapter



8 O-rings



Pre-filter Housing Wrench



Membrane Housing Wrench



Faucet Hanger



Locking Clips



3/8" Tubing



1/4" Tubing

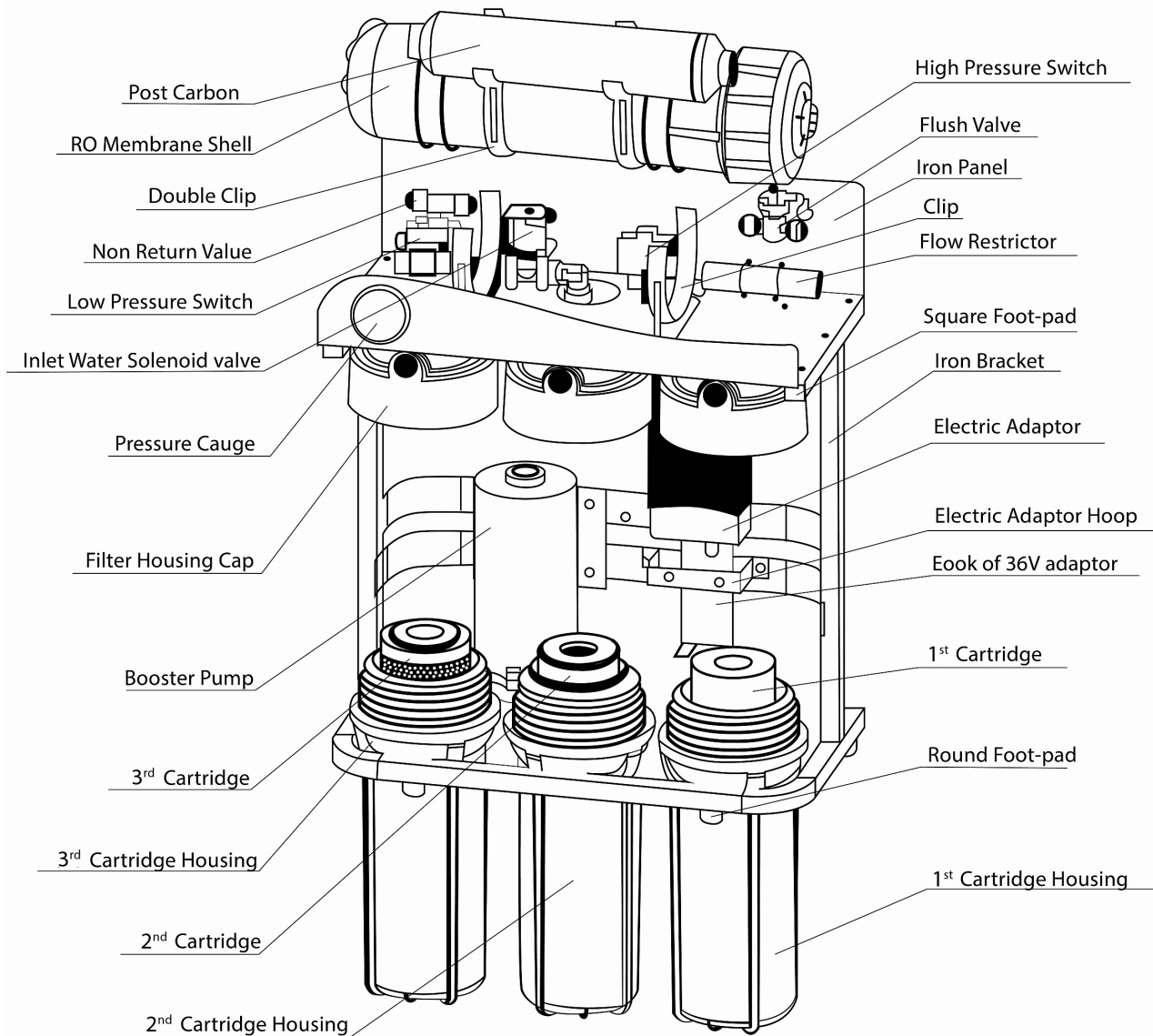

## Installation Tips

### *How to Use Quick-connect Fitting*



### To Connect:

1. See Figures above. Check and cut the tubing end square and clean with a utility knife or scissors.
2. Make a mark at the end of tubing. The length is about 1/2" - the depth of the fitting body.
3. Fully insert the tubing until the mark is almost invisible. This ensures that it is sealed by the O-ring near the bottom.

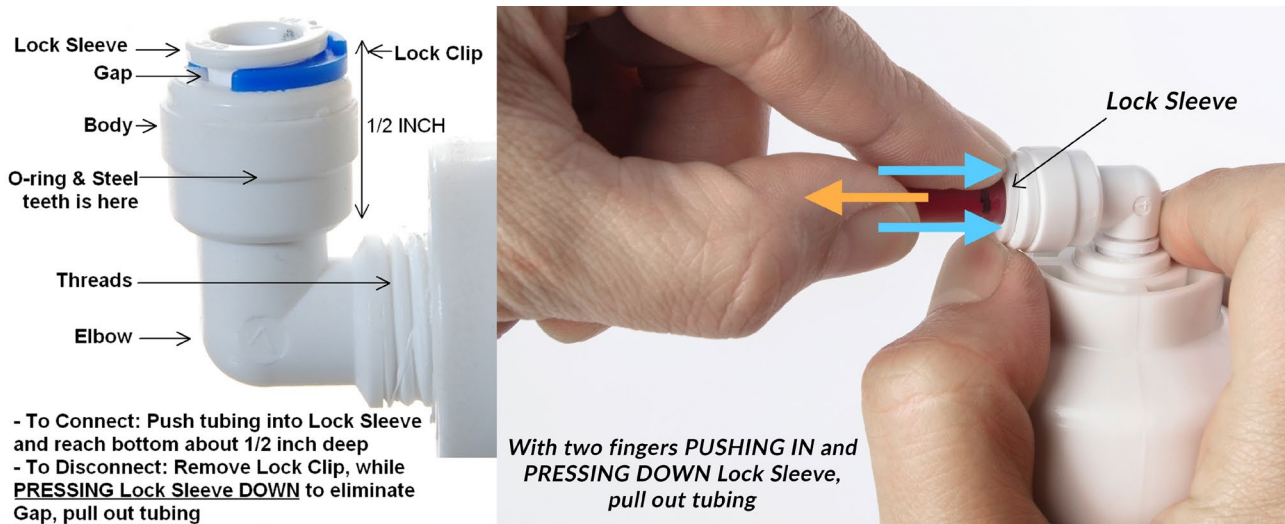

### To Disconnect:

1. See Figures above. Remove the blue Lock Clip.
2. With two fingers **PUSHING IN** and **PRESSING DOWN** the Lock Sleeve to eliminate the Gap that the blue Lock Clip occupied, pull the tubing out. (Pressing down the Lock Sleeve releases the spring-loaded steel teeth that grab the tubing inside the fitting body.)

### How to Use Compression Fitting with Brass Nut, Collar, and Tube Insert

Compression fitting is used to connect the PVC tubing to the threaded metal inlet with a tapered open end, such as the refrigerator water inlet, drinking faucet water inlet, etc.

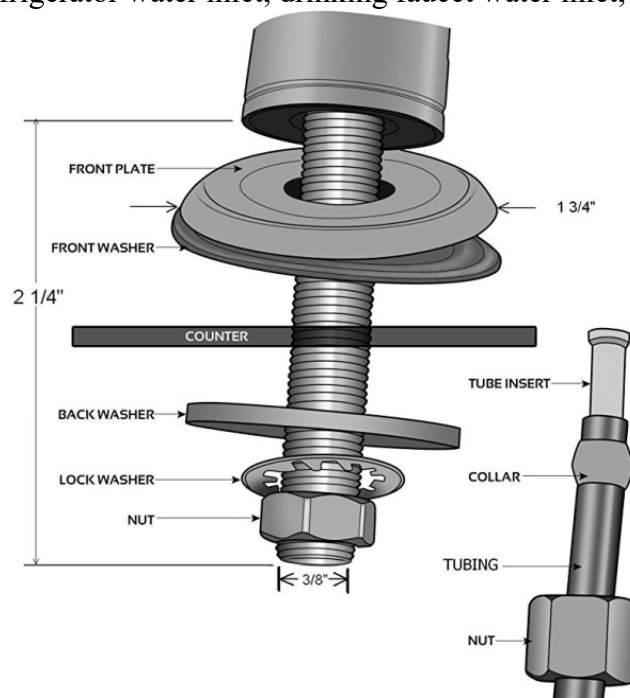

1. Slide the Nut and Collar onto the end of tubing.
2. Fully insert the Insert into the open end of tubing.
3. Slide the Collar toward the Insert and fit into the tapered open end of the thread metal inlet.
4. Screw on the Nut and tighten it up. The Nut compresses the plastic Collar onto the tapered metal surface and creates a water seal between them while the Insert hardens the tubing.

### ***How to Drill a Hole in Sink or Counter-top***

1. It's highly recommended that you watch the YouTube video "How To Drill Faucet Holes."
2. Choose a half inch Diamond Core Bit for granite and a titanium drill bit for steel. Do NOT use a hammer drill on natural stone, glass, and ceramic.
3. An indent should be made with a punch on steel before drilling to help guide the bit.
4. Use caution when drilling on a Porcelain sink, as it could be easily chipped. Set drill speed on slow. Press the bit downward firmly until breaking through the slippery surface.
5. Use coolant to disperse heat. Choose water for granite and oil for steel. Use the Water Suction Cup to hold coolant inside and prevent the drill bit from slipping.
6. Starting at the slowest speed, hold the drill firmly and vertically to prevent the drill bit from slipping on the counter.
7. Once breaking through the smooth surface, swirl the drill a little to apply pressure in a circle evenly.
8. Be patient and deliberate. It can take 20 – 40 minutes to drill through one inch.

### ***Ice Maker Kit***

An Ice Maker Kit (part# iSpring **ICEK**) can be purchased separately to feed RO water to refrigerator and get crystal clear ice cubes and great tasting water at ease. It could make the Drinking Water Faucet not absolutely necessary.



## Installation Steps



Before you begin installation, it is highly recommended that you watch the video “iSpring reverse osmosis installation” on YouTube.

**Note:** Steps 1 – 7 are independent, and can be performed in any order.

### ***Step 1: Install Feed Water Adapter (AFW)***

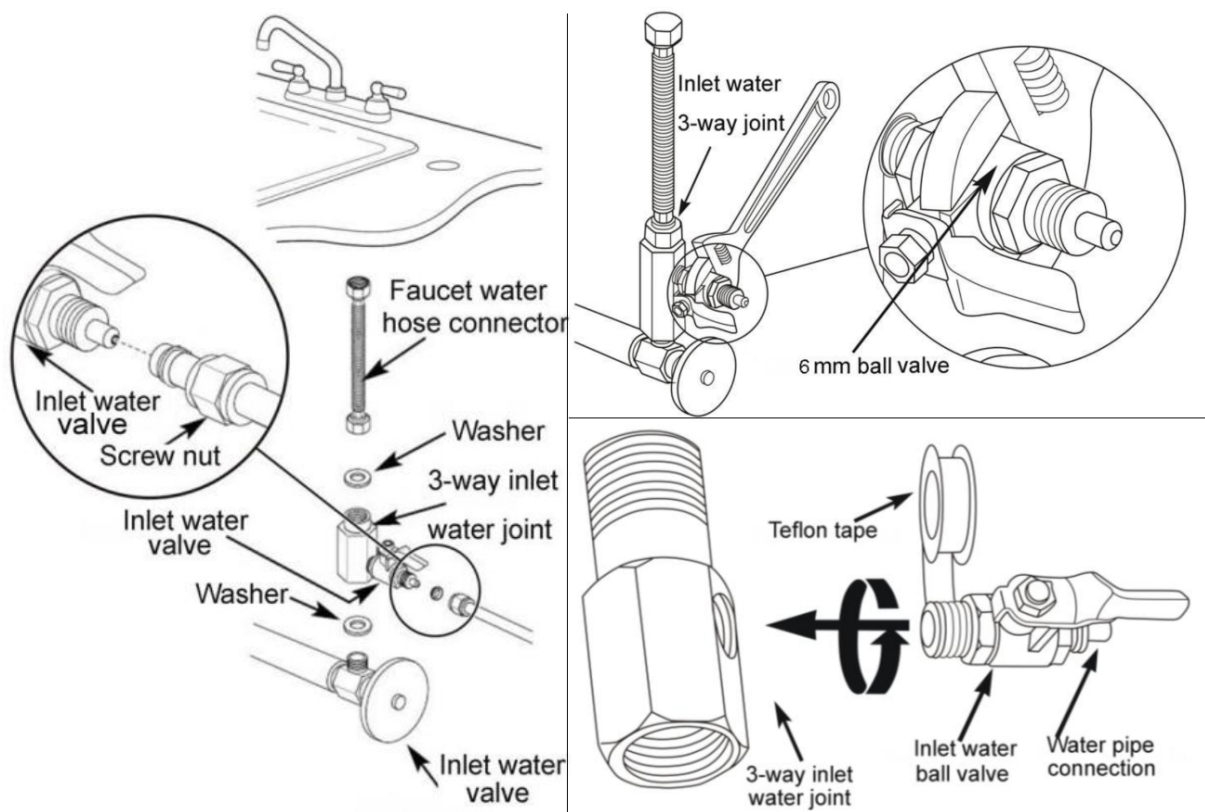

- 1.1 See Figures above. Turn off the Cold Water Line via the cold Water Supply Valve (WSV) under the sink. Open the kitchen faucet to release pressure and make sure water has stopped before proceeding to the next step. Get a towel or bucket to catch any water drips. Disconnect Faucet water hose Connector (FC) pipe from WSV.
- 1.2 Check O-ring inside AFW female end, and twist it onto WSV. Tighten it up using a wrench or pliers.
- 1.3 Twist FC onto the male end of AFW. Turn the handle of AFW to cross (OFF) position. Turn on WSV slowly, check for and fix any leaks.

## Step 2: Install Drinking Water Faucet

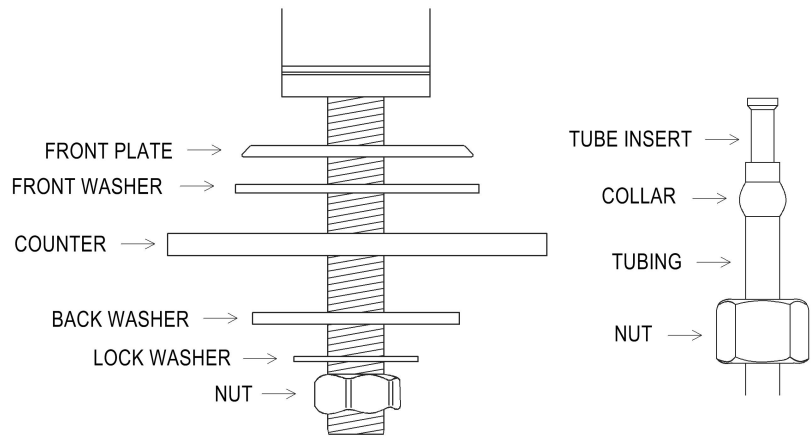

- 2.1 If your kitchen sink does not have an existing 1/2" hole, you will have to drill one. (Refer to *How to Drill a Hole in Sink or Counter-top.*) Wipe clean and dry the area. (Contact us for a larger front plate and washer if the hole is too big to cover.)
- 2.2 Remove the blue protection film from the front plate, slip it onto the faucet thread, and slip on the black rubber washer. Insert the faucet thread portion into the hole. Optional plumber glue or sealer could be used.
- 2.3 Under the sink, tighten the back rubber washer, lock washer with nut.
- 2.4 (Refer to *How to use compression fitting.*) Slip the compression fitting nut and collar onto the tubing, push the insert into the tubing, insert it into the faucet end, and tighten up the nut. Pull on the tubing to check if it is secure.

## Step 3: Install Drain Saddle



- 3.1 Choose a spot on the drain pipe that is convenient for installing the drain saddle and tubing. A horizontal pipe is recommended to minimize the dripping sound.
- 3.2 Drill a 1/4" hole on the drain pipe; paste the black sticky pad around the hole.
- 3.3 Cut off the 1/4" tubing end a bit to form a 45-degree angle. Slip the plastic nut and front plate onto the tubing. Insert the tubing into the 1/4" hole in the drain pipe, install the back plate and tighten two screws with hex nuts while the tubing remains in the hole.
- 3.4 Tighten the nut on the Drain Saddle by hand. Pull on the tubing to check if it is secure.

### ***Step 4: Install the Vertical Filters: Stages 1, 2, and 3***

- 4.1 Make sure that the O-ring is seated inside the groove at the top of the filter housing. Food-grade **silicon** jelly may be used to help the O-ring stay in place and seal better.
- 4.2 Filter cartridges are preserved in shrink wrap. Take note of the direction sign on the sticker before removing the wrap (GAC stage).
- 4.3 When placing the filter cartridge into its housing, make sure it is centered and the knob protruding from the bottom of the housing fits in the central hole of the filter.
- 4.4 Screw the housing, with filters attached, onto the housing caps (caps are pre-assembled on the machine head). The cap also has a center knob which should be inserted into the center hole of the filter cartridge. Twist the housing on in a clockwise direction by hand, and then use a housing wrench to tighten it up for about 1/4 – 1/2 turn. **Do not over tighten. This can cause leaks and make it difficult to unscrew the housing when replacing filters.**
- 4.5 Follow the steps 4.1 – 4.4 to install the GAC and CTO filters. \*Note\* the second stage GAC is the only filter that must go in a certain direction. Make sure that the end with the rubber washer faces up, thereby attaching to the housing cap.

**Double O-ring Clear Housing**



### ***Step 5: Install Tank Shut-off Valve (Optional)***

- 5.1 Optionally this RO system can be used with a 20 – 200 gallons storage tank. A tank helps meet the impulsive high volume demand and build a commercial or whole house Reverse Osmosis solution.
- 5.2 Wrap 10 - 15 turns of Teflon tape clockwise (looking from top) onto the metal thread at the top of the tank.
- 5.3 Screw (clockwise) the Tank Shut-off Valve on and tighten up by hand. Do not over tighten.
- 5.4 An extra Tee fitting is needed for connecting the 5<sup>th</sup> stage, tank and filtered water faucet.

### ***Step 6: Install Reverse Osmosis Membrane***

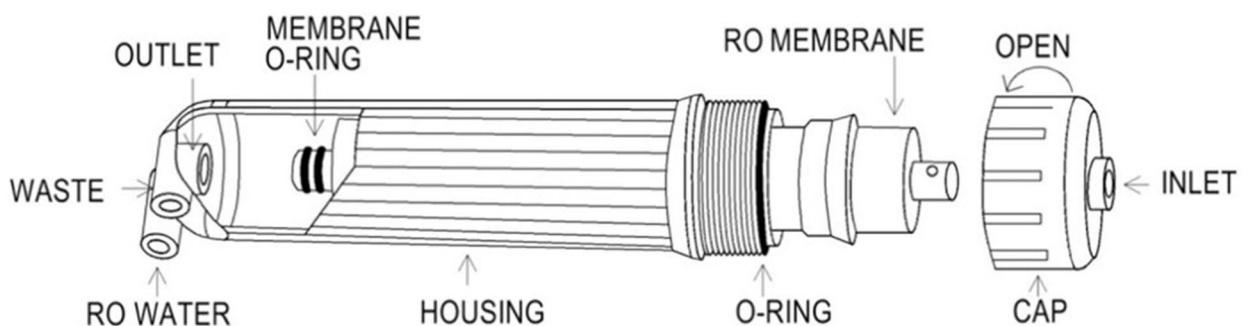

- 6.1 Open the membrane housing cap. A thick rubber band can be slipped on the housing body for better grip.
- 6.2 Find the **inner end with 4 O-rings**, cut open the end of sealed bag and use it to hold RO membrane to avoid contamination, and firmly insert the membrane into the housing until the outer end with only 2 O-rings is completely inside the housing. See Figure above.
- 6.3 Before twisting the housing cap back on, check that the **O-ring is evenly snagged on the membrane housing (cap does NOT have O-ring)**. Hang tight and tighten up for about 1/4 – 1/2 turns using a small plastic housing wrench, but do not over tighten. DO NOT reconnect the tubing to inlet on cap at this point (will do it in system start up).

### Step 7: Tubing Hook Up (optional sub-steps are marked with \*)



- A** Source water INPUT from Feed Water Adapter
- B** Clean water OUTPUT to Drinking Faucet
- C** Waste water OUTPUT to Drain Saddle

- 7.1 Facing the iSpring logo up front, locate the pre-filter 1<sup>st</sup> stage on the right hand side. Connect the 3/8" tubing between Feed Water Adapter (AFW) and point A.
- 7.2 Connect the Flow Restrictor (point C), which is a 3" long cylinder with a FLOW sign laying beside the membrane housing, to the black Drain Saddle with 1/4" tubing.
- 7.3 Connect the Post Carbon Filter FT15 5<sup>th</sup> stage (point B) to the RO faucet with 1/4" tubing.

\* If you have a RO storage tank, replace the elbow fitting at point D with a Tee fitting, reconnect the tubing from the check valve to one T, and connect the other T with tank shut-off valve.

### ***Step 8: System Start Up (optional sub-steps are marked with \*)***

- 8.1 Make sure that none of the tubings are kinked. Prepare a bath towel and bucket to catch water drips.
- 8.2 To avoid the residual carbon dust in the first three stages from getting into the RO membrane, remove the tubing to the inlet of the RO membrane housing cap. Flush the first three stages into a bucket until the water turns clear, and re-connect the tubing to the RO membrane. You may do this whenever you change the first three stages. (Optional: disconnect the storage tank if you have one)
- 8.3 Plug in booster pump power. Turn on Feed Water Adapter valve (AFW), and then slowly turn on the cold Water Supply Valve (WSV). Finish flushing the first 3 stages, and then reconnect the tubing to membrane housing cap.
- 8.4 **Check for leaks.** The top 3 causes for leaks are:
  - 1) The tubing was not fully inserted into the quick-connect fitting.
  - 2) The O-ring was not in place or kinked.
  - 3) The Housing/Cap was not tightened up or off threads.
- 8.5 Turn on RO faucet. Within 5 minutes, RO water should start dripping. Let it run for at least 10 minutes. This flushes the system. Water could be black due to fine carbon dust from new carbon filters (step 8.2 could be taken to expedite the flush). It will turn clear with some air bubbles. Shut off the RO Faucet. (Optional: turn on the Tank Shut-off Valve and wait for the tank to be filled up.)

\* If you have installed an iSpring UV stage, plug in the UV power and observe if the RO faucet turns the UV on/off through the Flow Sensor Switch.

- 8.6 The reverse osmosis membrane is the key part for the effective reduction of total dissolved solids (TDS) and the produced water should be tested periodically to verify that the system is performing properly. If the TDS of the source water is 100 ppm, the RO water should be less than 10 ppm (Rejection rate >90%).
- 8.7 Check for leaks daily for the first two weeks after installation. Furthermore, a tray can be put under the system in case of any leaks, and a Flood Alarm can be used together for better protection.

**Congratulations! You have successfully installed the  
iSpring Reverse Osmosis Water Filtration System!  
Start enjoying the cleanest water right from your tap!**

## System Maintenance

# FILTER CARTRIDGE REPLACEMENT SCHEDULE



STAGE 1	STAGE 2	STAGE 3	STAGE 4	STAGE 5
Sediment #FP15	GAC #FG15	CTO #FC15	RO Membrane #MS5	T33 Fine Carbon #FT15
<b>6-12 months</b>	<b>6-12 months</b>	<b>6-12 months</b>	<b>1-3 years</b>	<b>12 months</b>

Many vendors claim their filters will last longer than 6 months in order to make a sale. Professional opinion and industry standards suggest changing the filters no later than every 6 months to minimize contamination risks and ensure the intended filtration performance.

For replacement filter cartridges, visit [123Filter.com](http://123Filter.com) or Google “Model replacement filter” online, in which “Model” is the model number of the system, e.g. RCS5T.

### ***Stages 1 – 3 Pre-filters: Replace every 6 – 12 months, depending on source water quality and clean water usage.***

The frequency depends on the source water quality and clean water usage. They could last longer in city water, and shorter in well water. Different areas have good or bad water. Some customers reported they had to replace the 1st stage every 1-3 months when they saw through the clear housing where heavy sediments and particles turned the white cartridge into a dark brown color. Some customers reported they could replace them every 12 months. To protect the RO membrane in the 4<sup>th</sup> stage, it is **required** to replace the pre-filters **at least every 12 months**.

### ***How to Change In-housing Cartridges in 1<sup>st</sup> – 3<sup>rd</sup> Pre-filter Stages***

1. Shut off the water supply valve and tank valve, open the faucet to depressurize. Place a bucket or towel under the unit to catch water spills.

2. If there is enough room under the sink and filter system is hung on the wall, it could be easier to twist the filter housing off without taking the unit off the wall. Otherwise, it could be easier to pull the system out, lay it down and work towards the housing bottom. Please be careful with tubing connections when pulling the system out.
3. Twist off the filter housing in a counter-clockwise direction when looking from the bottom. Use a housing wrench (the bigger one) if necessary.
4. Refer to Installation Step 4.1 to install a new vertical filter cartridges and twist the housings back on. Remember not to over tighten or it will be hard to open next time.

### ***Stage 4 RO Membrane: Replace every 2 – 3 years or sooner if TDS level starts increasing.***

Check the TDS level at least once a month to monitor the system performance. The rejection rate should be above 90% (NSF/ANSI STANDARD 58 for RO water filter).

### ***How to Change Reverse Osmosis Membrane***

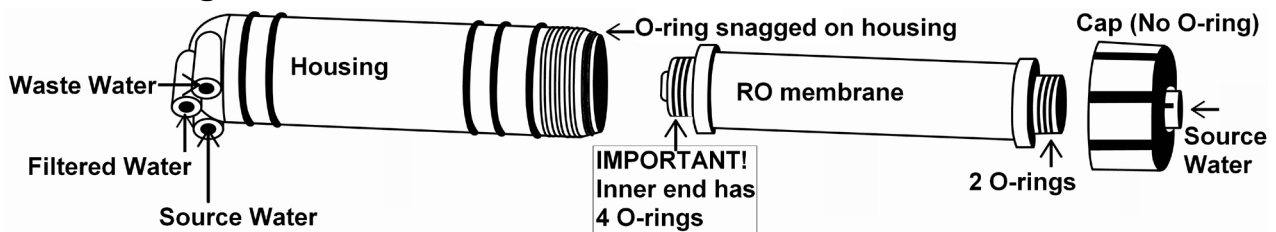

1. Reverse osmosis membrane usually last about 2 – 3 years, depending on the source water quality, clean water usage and the replacement frequency of the three pre-filters.
2. To ensure system performance and water purity, filter cartridges must be replaced on schedule. Use the TDS meter periodically to check rejection rate.
3. Shut off the water supply valve and (optional) tank valve, open the faucet to depressurize
4. Place a bucket or towel under the unit to catch water spills.
5. Remove the tubing from the inlet fitting on the membrane housing cap. Use a housing wrench or by hand to twist off the housing cap in a counter-clockwise direction when looking from inlet. Pull out the old membrane. Use scissors or pliers to apply leverage if necessary.
6. Clean the housing using hot water and optional scent-free dish soap. Rinse thoroughly. Cut open the small end of the sealed bag of a new RO membrane, hold the new membrane with the bag, and insert it into housing without touching the membrane with your bare hands, which may contaminate it.
7. Check the O-ring on the open end of the membrane housing. It is recommended to replace it every 3 years to prevent leaks. Twist the membrane housing cap back on by hand. Use a wrench for a final 1/4 turn if necessary. DO NOT over tighten.

### ***Stage 5 T33 Fine Carbon: Replace every 12 months***

Unscrew the elbow fittings on both ends, put them on the new cartridge, and use new Teflon if necessary.

### ***How to Change Inline Cartridges in 5<sup>th</sup> – 7<sup>th</sup> Stages***

1. Please note that the 5<sup>th</sup> - 7<sup>th</sup> stages (model specific) have directions and each end may have a different kind of fitting.

2. Disconnect the tubing from the Quick-Connect fitting, unscrew the fitting, unwrap a new cartridge, replace the Teflon tape on the fitting threads if necessary, follow the → sign on the label to screw the correct fitting on each end, and reconnect the tubing.

***O-rings: Replace every 3 years or sooner if leak happens at O-ring.***

The package comes with 3 spare O-rings for the pre-filter housing, and 1 spare O-ring for the membrane housing. Please save them with this manual.

## **Extra Installation**

### ***UV Lamp (part# iSpring UVF11A) and Ice Maker Kit (part# iSpring ICEK)***



The models with a UV stage have a “U” letter in model number, such as **RCC7U**, **RCCAK-UV**, **RCC1UP-AK**.

The UV module comes pre-installed on the models with UV. It should function out of the box. The images above are for a better understanding on how the components are assembled and work together.

The Ice Maker Kit (model# iSpring **ICEK**) can be purchased separately to feed RO water to a refrigerator and get crystal clear ice cubes and great tasting water. It would make a Drinking Water Faucet not necessary.



## **Warranty Registration**

**To register your product for the warranty, visit our website at [123filter.com](http://123filter.com) and go to the “Warranty” tab.**

We provide a 30-day money-back guarantee, a 1-year manufacturer warranty, and lifetime tech support for all of our products. However, we do not have the order information from websites other than 123Filter.com (Amazon, Home Depot, etc.), so please be sure to fill in that information upon registration of your system. If you have any questions or concerns about your product, please do not hesitate to call or email us, or put it in the notes/comments upon your warranty registration. Your satisfaction is our business!

**If you are happy with our products and service, please show your support by writing a product review on Amazon, even just a single line. It takes you just a minute but means a lot to us. Thank you!**





Atlanta, GA USA

**iSpringFilter.com**

For questions, comments, or technical support, please contact us at:

[support@123Filter.com](mailto:support@123Filter.com)

(678) 261-7611

Monday-Friday 8:30 a.m. - 5:30 p.m. EST